

ESTIMATED MASS: 62.00 kg

PARTS LIST		
ITEM	QTY	DESCRIPTION
PB-S-01\ITEM 1	1	BARRIER WELDED ASSEMBLY

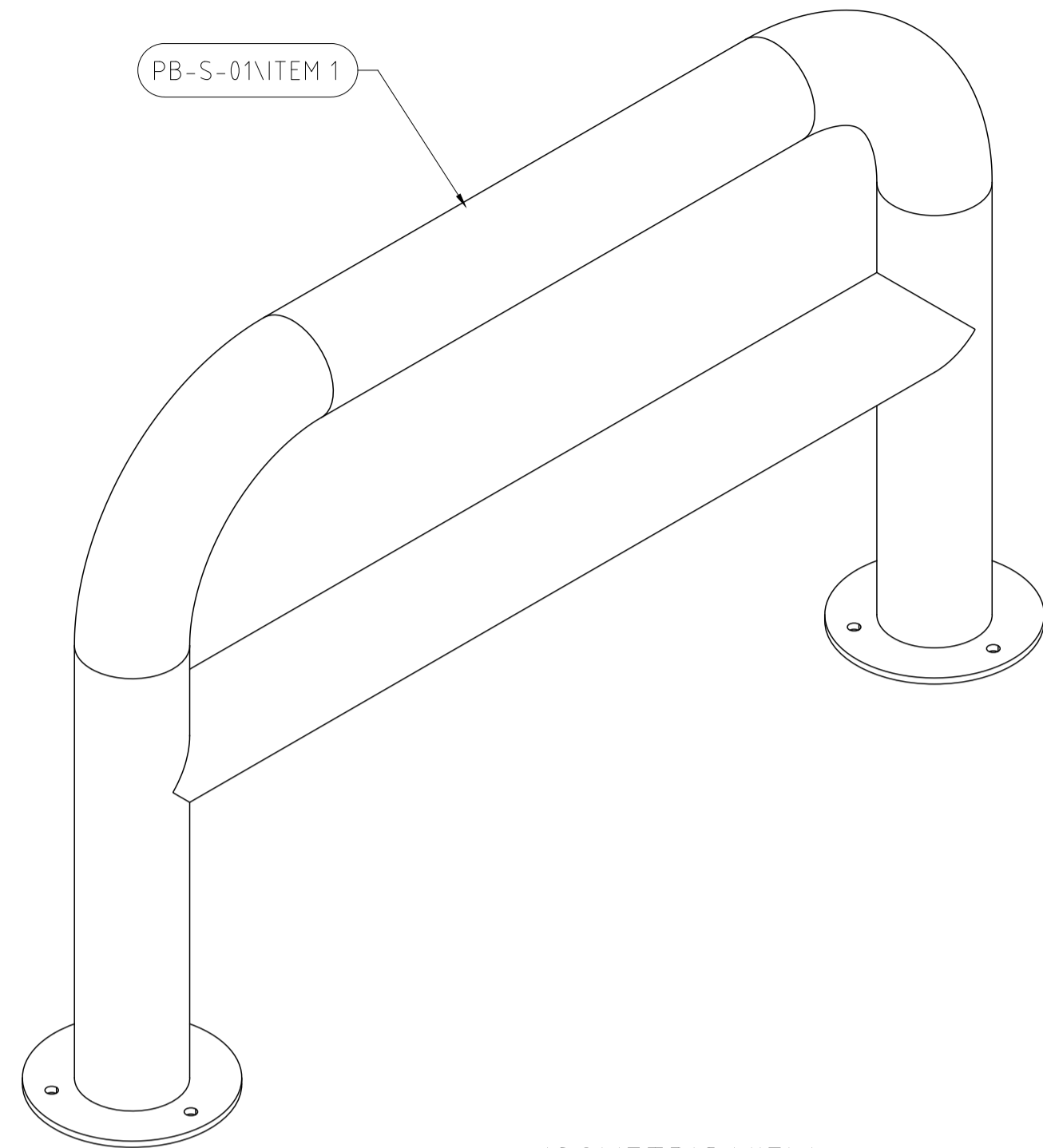

ISOMETRIC VIEW
PB-S-01

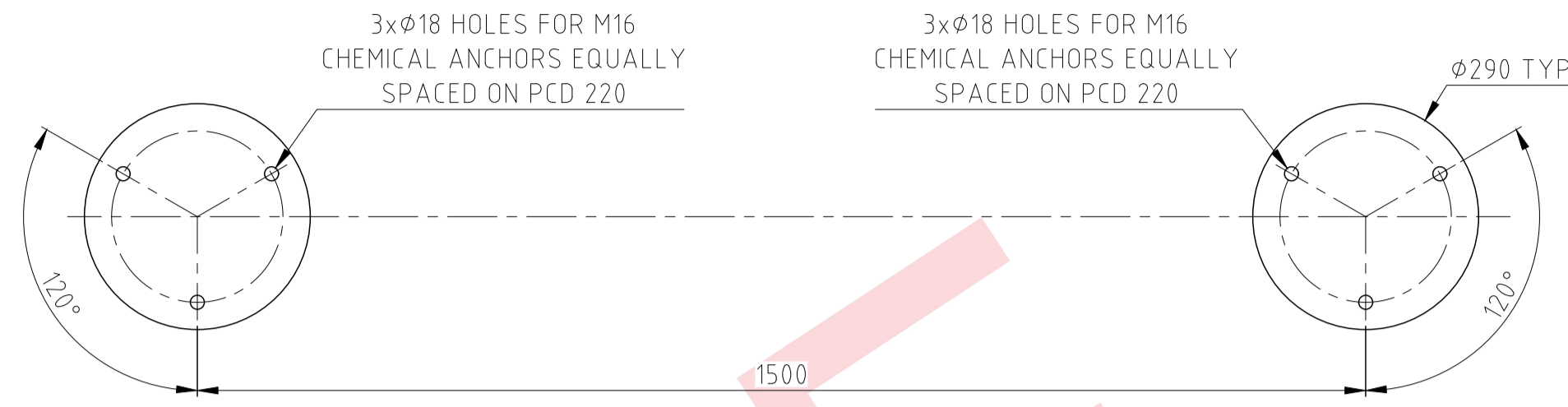

DRILLING DETAIL
PB-S-01

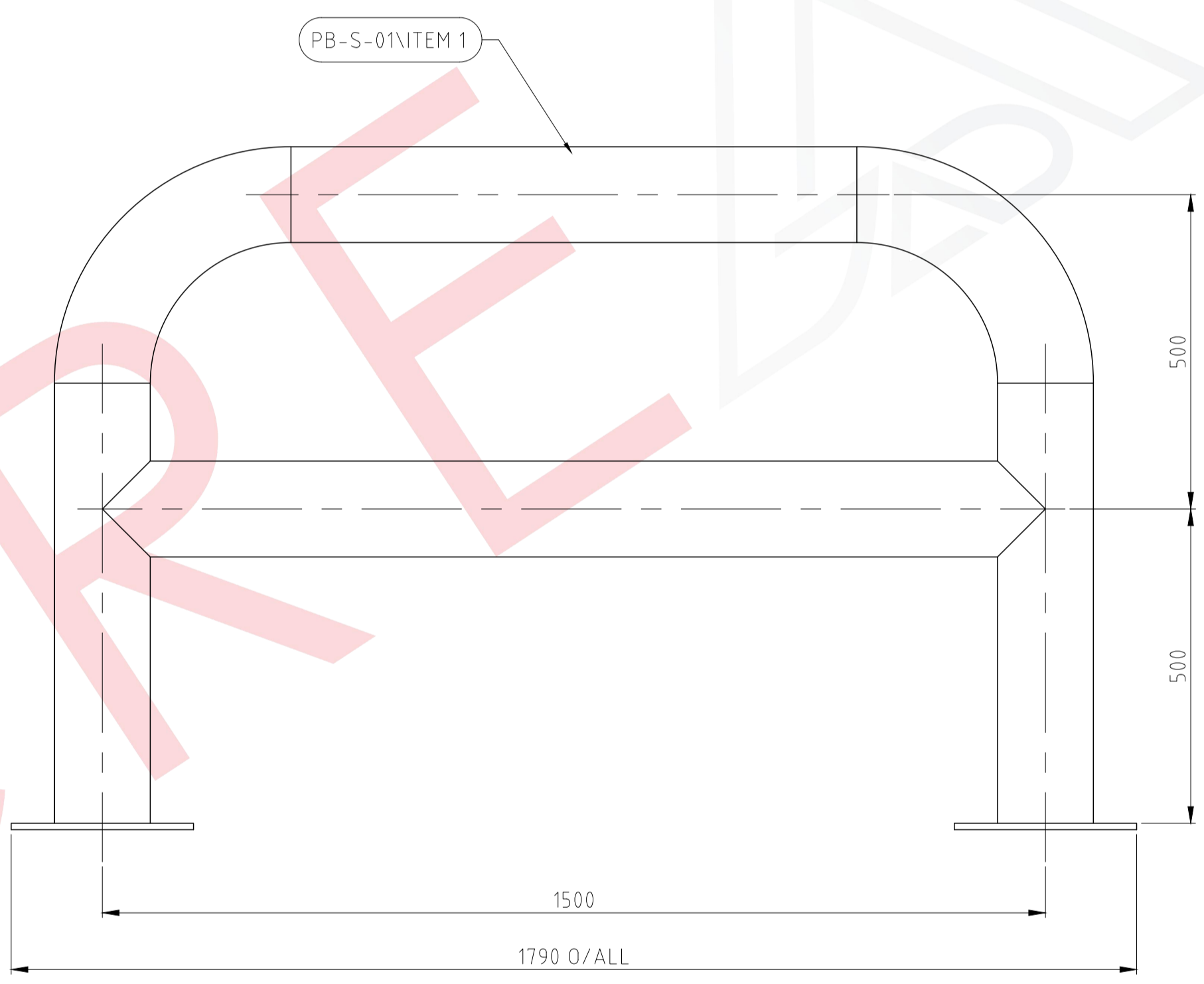

FRONT VIEW
PB-S-01

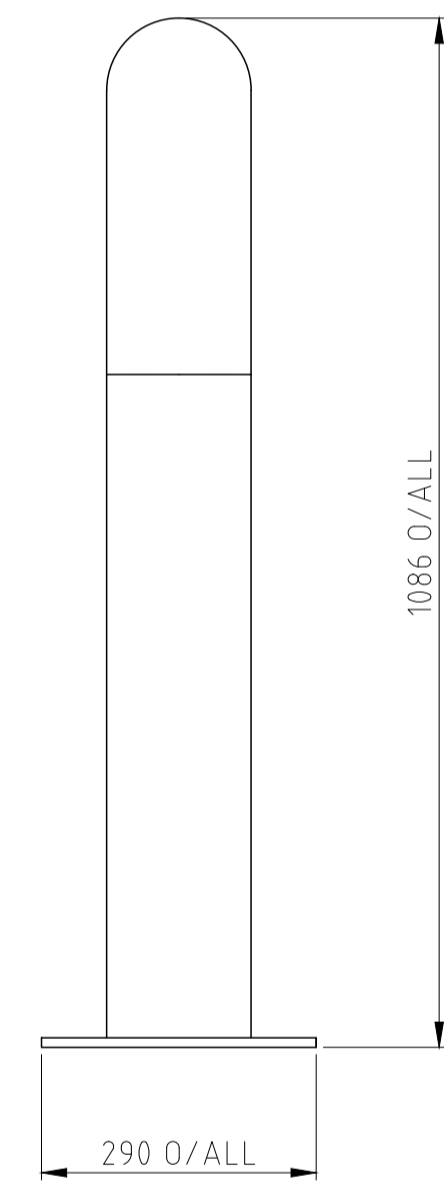

RIGHT VIEW

GENERAL NOTES

1. ALL DIMENSIONS IN mm, U.O.N.
2. STRUCTURAL STEEL IS IN ACCORDANCE WITH GENERAL SPECIFICATION REF. SANS 10162.
3. FOR ALL OTHER NOTES PLEASE REFER TO THE USER MANUAL.

REFERENCE DRAWINGS		REVISION TABLE			
DRAWING NUMBER	DESCRIPTION	REV	DATE	DESCRIPTION	BY
		0	20/01/2025	FOR INFORMATION ONLY	T.K

THIS DRAWING IS THE PROPERTY OF CREATE AND MAY NOT BE COPIED OR REPRODUCED EITHER IN WHOLLY OR IN PART WITHOUT THE WRITTEN PERMISSION OF THE ABOVEMENTIONED COMPANY.



Cell: +27 60 890 8171
Email: create@jadengineering.co.za

ITEM PB-S-01 PARKING BARRIER STRAIGHT IDENTIFICATION DRAWING ASSEMBLY		
DRAWING NUMBER CRT-PB-S-01-I-R0		
SHEET 1 OF 1	REV 0	A1
PROJECTION 		
DRAWN BY:	T.K	
CHECKED BY:	P.H	
SCALE:	NTS	