

ESTIMATED MASS: 39.00 kg

PARTS LIST		
ITEM	Q.TY	DESCRIPTION
PT-01\ITEM 1	1	TROLLEY BODY
PT-01\ITEM 2	2	Ø320 WHEEL
PT-01\ITEM 3	4	RUBBER ASSEMBLY
PT-01\ITEM 4	6	WEAR BAR
PT-01\ITEM 5	18	M4 x 30mm LNG CSK BOLT ASSEMBLY
PT-01\ITEM 6	2	Ø4 x 35mm LNG SPLITPIN
PT-01\ITEM 7	4	WASHER

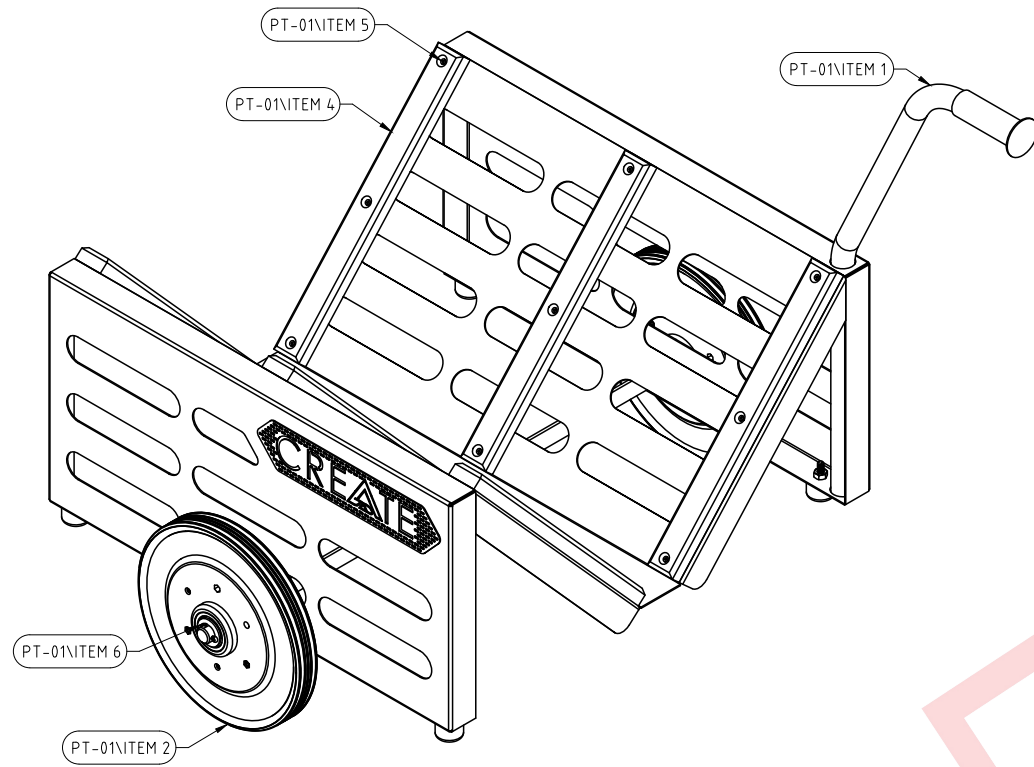

ISOMETRIC VIEW 1
PT-01

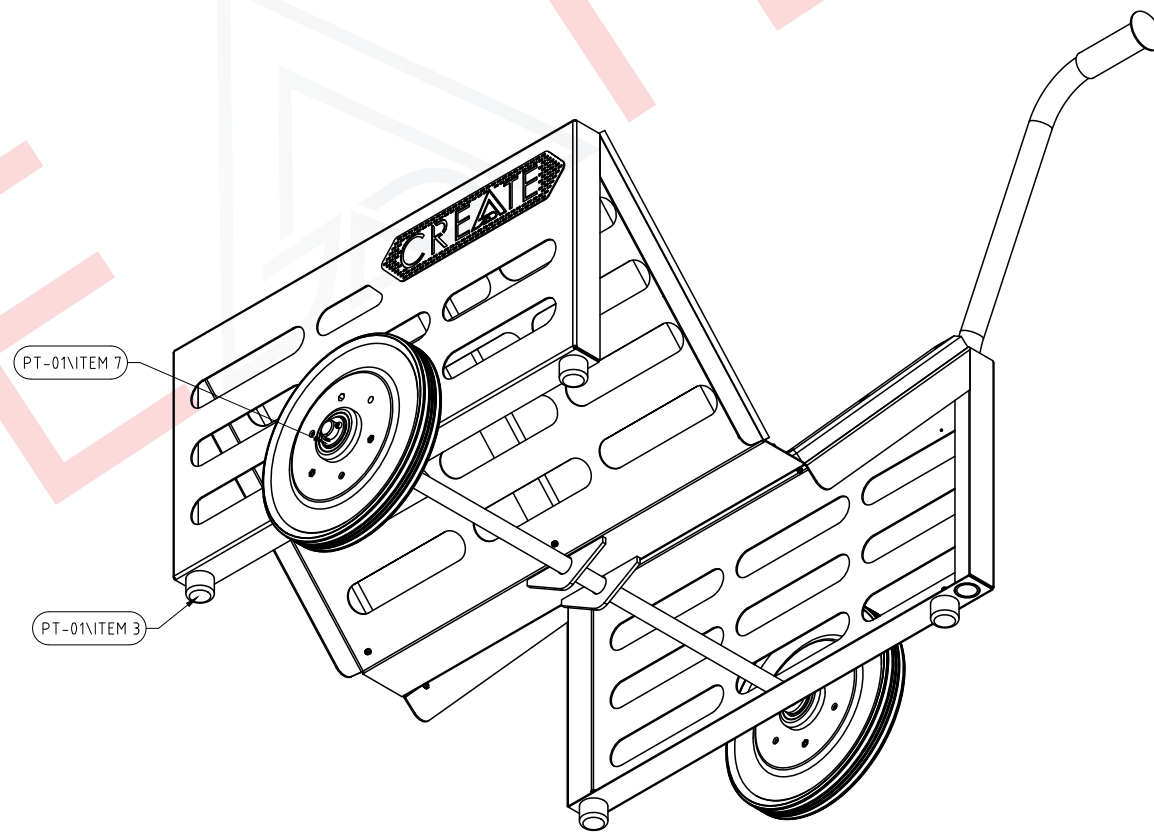

ISOMETRIC VIEW 2
PT-01

GENERAL NOTES

- ALL DIMENSIONS IN mm, U.O.N.
- STRUCTURAL STEEL IS IN ACCORDANCE WITH GENERAL SPECIFICATION REF. SANS 10162.
- FOR ALL OTHER NOTES PLEASE REFER TO THE USER MANUAL.

ITEM
PT-01 PIPE TROLLEY
IDENTIFICATION DRAWING
GENERAL ARRANGEMENT
S.W.L. 500 kg

REFERENCE DRAWINGS		REVISION TABLE			
DRAWING NUMBER	DESCRIPTION	REV	DATE	DESCRIPTION	BY
CRT-PT-01-I-R0 SHEET 2 OF 2	ASSEMBLY	0	15/01/2025	FOR INFORMATION ONLY	T.K

THIS DRAWING IS THE PROPERTY OF CREATE AND MAY NOT BE COPIED OR REPRODUCED EITHER IN WHOLLY OR IN PART WITHOUT THE WRITTEN PERMISSION OF THE ABOVEMENTIONED COMPANY.



Cell: +27 60 890 8171
Email: create@jadengineering.co.za

DRAWING NUMBER CRT-PT-01-I-R0		
SHEET 1 OF 2	REV 0	A1
PROJECTION 		
DRAWN BY:	T.K	
CHECKED BY:	P.H	
SCALE:	NTS	

ESTIMATED MASS: 39.00 kg

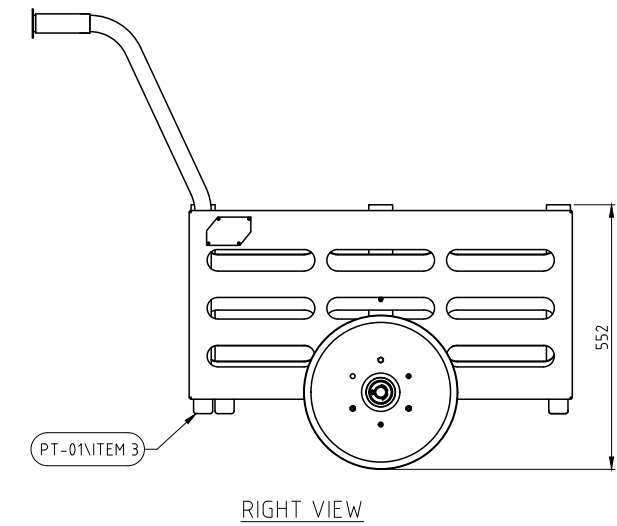
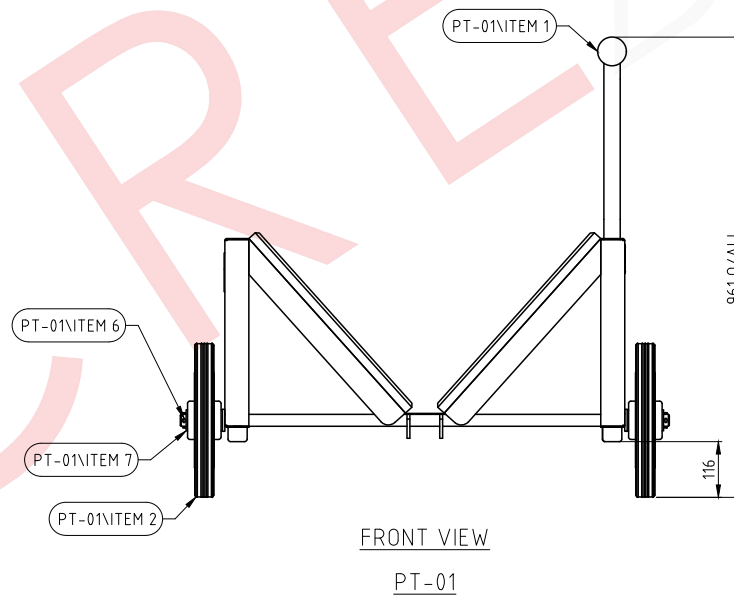
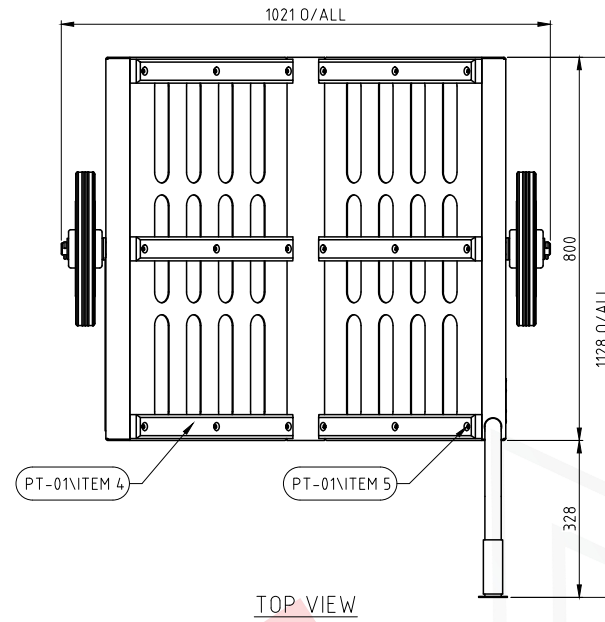
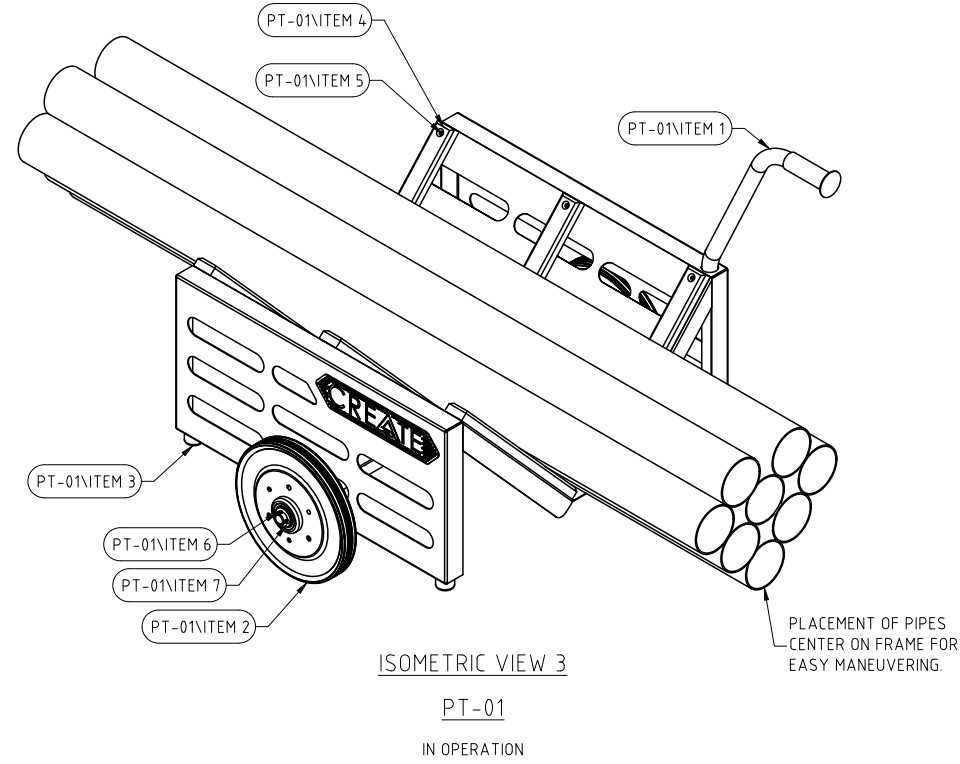

PARTS LIST		
ITEM	QTY	DESCRIPTION
PT-01\NITEM 1	1	TROLLEY BODY
PT-01\NITEM 2	2	Ø320 WHEEL
PT-01\NITEM 3	4	RUBBER ASSEMBLY
PT-01\NITEM 4	6	WEAR BAR
PT-01\NITEM 5	18	M4 x 30mm LNG CSK BOLT ASSEMBLY
PT-01\NITEM 6	2	Ø4 x 35mm LNG SPLITPIN
PT-01\NITEM 7	4	WASHER

GENERAL NOTES

- ALL DIMENSIONS IN mm, U.O.N.
- STRUCTURAL STEEL IS IN ACCORDANCE WITH GENERAL SPECIFICATION REF. SANS 10162.
- FOR ALL OTHER NOTES PLEASE REFER TO THE USER MANUAL.

REFERENCE DRAWINGS		REVISION TABLE			
DRAWING NUMBER	DESCRIPTION	REV	DATE	DESCRIPTION	BY
CRT-PT-01-I-R0 SHEET 1 OF 2	GENERAL ARRANGEMENT	0	15/01/2025	FOR INFORMATION ONLY	T.K

THIS DRAWING IS THE PROPERTY OF CREATE AND MAY NOT BE COPIED OR REPRODUCED EITHER IN WHOLLY OR IN PART WITHOUT THE WRITTEN PERMISSION OF THE ABOVEMENTIONED COMPANY.



Cell: +27 60 890 8171
Email: create@jadengineering.co.za

ITEM
PT-01 PIPE TROLLEY
IDENTIFICATION DRAWING
ASSEMBLY
S.W.L. 500 kg

DRAWING NUMBER
CRT-PT-01-I-R0

SHEET 2 OF 2 REV 0 A1

PROJECTION

DRAWN BY: T.K

CHECKED BY: P.H

SCALE: NTS